

Owner's Manual

Olympic Versa-Lift™

Model 50701, 50703

Serial # _____

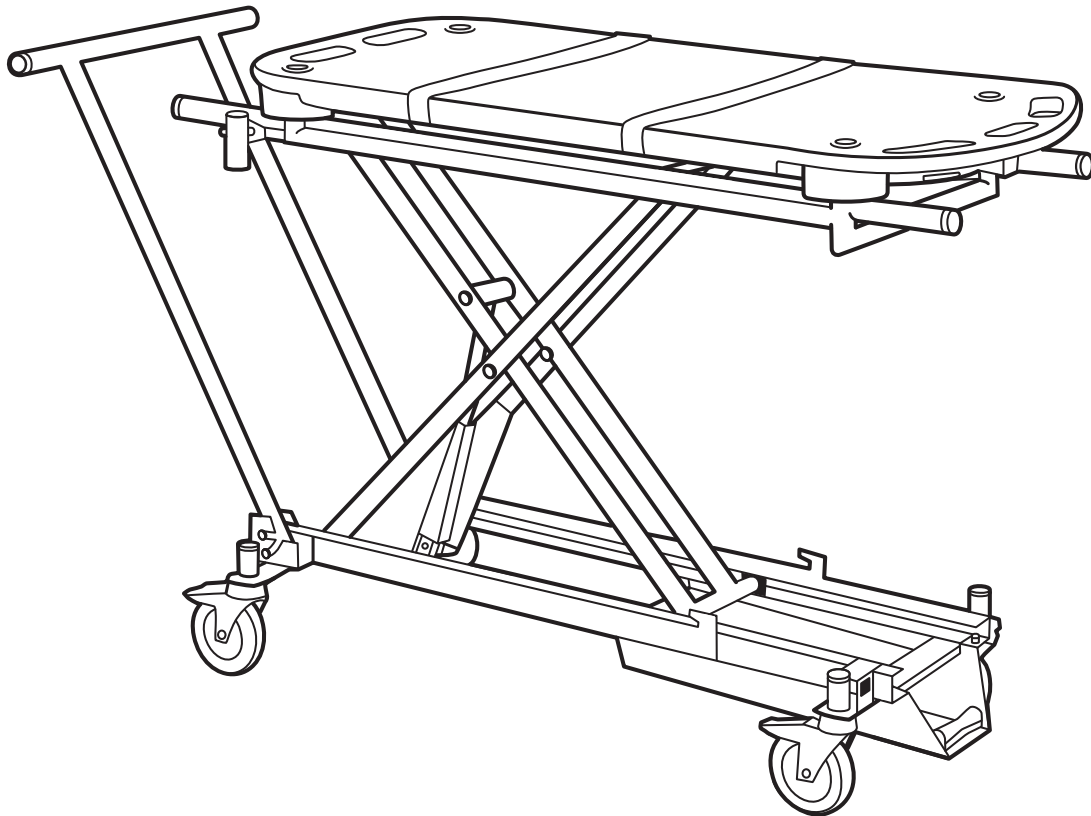

9311 SE 36th Street, Unit 220
Mercer Island, WA 98040

Phone: 800-789-6867 • **Fax** 206-905-0839

Web: www.OlympicVeterinary.com

Email: Info@OlyVet.com

About this Manual

This manual contains information on the setup, use and upkeep of the Olympic Versa-Lift and should be read in its entirety before first use to assure safe operation and optimal performance.

This lift has a serial number you will need to reference when seeking technical support. This is located directly behind the Power Plug. For future reference, it is recommended you write this serial number on the front of this manual.

Table of Contents

Component Identification.....	3
Introduction	4
Quick-Start Instructions.....	4
Safety	5
Unpacking and Set-Up	5
Operation	5
Loading and Unloading	5
Height Adjustment	6
Steering and Braking.....	6
Interchangeable Tops	6
Low Boy Handle.....	7
IV Pole.....	7
Swivelling Instrument Tray (optional)	7
Headrest for Olympic Versa-Lift (optional).....	7
Battery	7
Connecting the Power Cord	7
Charging	7
Indicators.....	8
Preventive Maintenance.....	8
Cleaning.....	8
Cleaning and Lubricating the Glide Channels.....	9
Lubricating and Inspecting Casters	9
Lubricating Pivot Points.....	9
Trouble Shooting.....	10
Specifications.....	10
Ordering Information	10
Optional accessories.....	11
Service	11
Replacement Parts.....	11
Warranty.....	12
Contact Us	12

List of Figures

Figure 1 – Component Identification.....	3
Figure 2 – Height Adjustment.....	6
Figure 3 – Caster Lubrication.....	9

Component Identification

The following illustration demonstrates the key components of the Olympic Versa-Lift.

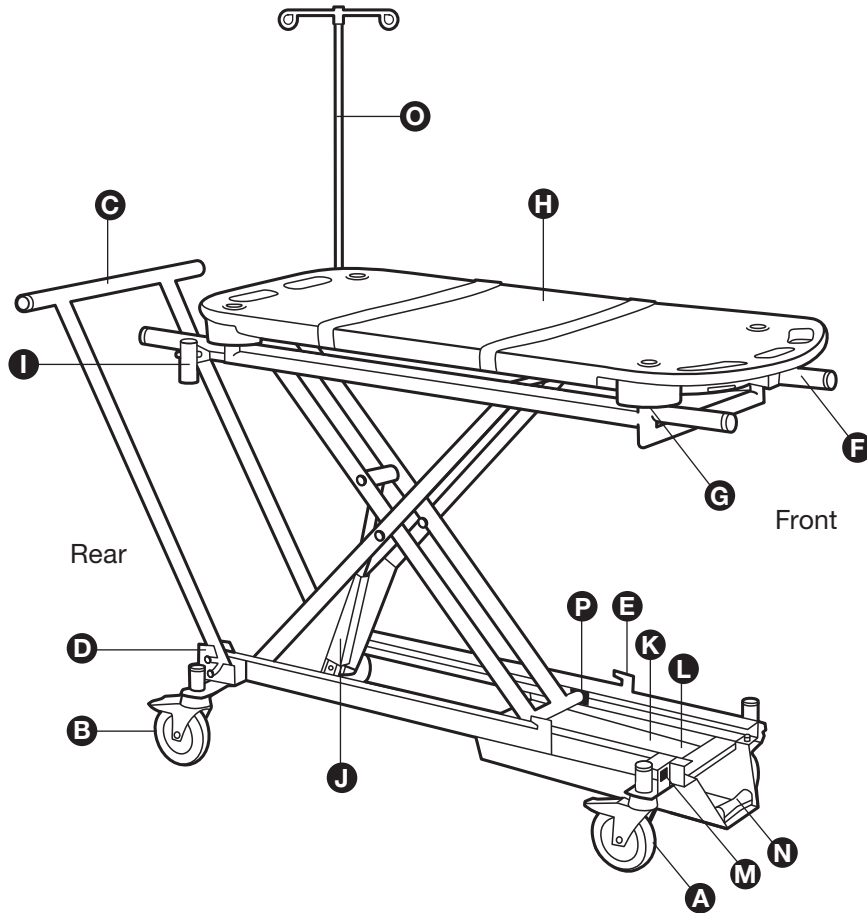

Figure 1

Item	Description	Item	Description
A	Front Total-Lock Casters (red tabs on brakes)	I	Accessory Sockets
B	Rear Directional Casters (green tabs on brakes)	J	Linear Actuator (lift mechanism)
C	Low-Boy Handle	K	Battery
D	Low-Boy Handle “Pin and Groove System”	L	Controller/Battery Charger
E	Low-Boy Handle Slide-in Retention Lock	M	AC Power Connector
F	Integrated Handles	N	Foot switch
G	Platform Retention Posts	O	IV Pole
H	Platform (Soft Stretcher or Hardtop Stretcher)	P	Gliders

Introduction

The Olympic Versa-Lift serves as a transport gurney, a low-boy transport, a lift table and a prep table. It is suitable for transporting or treating anesthetized or awake patients up to 250 pounds anywhere within the clinic or for meeting critical patients at the car.

Infinitely adjustable, it can quickly be set to the height of a cage, car seat, operating room table or any other surface up to 42 inches high. And it can be lowered to within 12 inches of the ground so you can easily unload heavy patients with minimal lifting. To assure it is always at the ready, the Versa-Lift is powered by a rechargeable battery with a built-in battery charger. Using a precision scissors drive system, operation is always smooth and quiet.

The lift incorporates Olympic's unique system of interchangeable tops, and comes with a Hard Top Stretcher and optional Soft Top Stretcher. Tops change out in seconds to accommodate any application. Extra large in-line locking casters and a lightweight design make the unit maneuverable in even the tightest spaces, and a built-in, pull-out handle allows the user to comfortably push the lift across a parking lot, even when fully lowered.

Quick-Start Instructions

Note: This section is intended for use only after you have read and familiarized yourself with the entire contents of this manual, including all safety precautions and warnings.

1. Plug the unit into a wall outlet for a minimum of 24 hours prior to first use to fully charge the battery. Failure to do so may compromise battery life.

Note: Be sure to unplug the unit before attempting to raise or lower the lift. As a safety precaution, the lift will not operate as long as the unit is still connected to AC power.

2. Familiarize yourself with the locking mechanisms on the 4 casters:
 - **Front Total-Lock Casters** (red tabs on brakes) – When engaged, prevent the lift from rolling forward or backward **A**.
 - **Rear Directional Casters** (green tabs on brakes) – When engaged, prevent the back end of the lift from swivelling, but without impeding forward movement **B**.

CAUTION: All 4 casters must be locked when used as a stationary treatment table.

3. Select the top you will need for this procedure – either the Soft Stretcher or the Hard Top Stretcher. You may change the top at any time by lifting it straight up off the 4 retention posts.
4. Lock or unlock casters based on how cart will be used:
 - **Normal transport** – Rolling and steering, all 4 casters unlocked.
 - **Stationary use** – Treatment Table, battery charging, loading, unloading, etc.
CAUTION: All 4 casters must be locked.
 - **Transporting heavier loads or when transporting over long distances** – 2 front casters (red tabs) unlocked. 2 rear casters (green tabs) locked. CAUTION: When transporting heavier loads, lift will not move sideways. Do not push lift sideways.
5. You may push or pull the unit using the integrated handles located directly under the upper platform **F**.
6. Raise or lower the platform as desired by pressing and holding the Foot switch **N**. Height should be adjusted only when the unit is stationary and the brakes are engaged.
7. When the upper platform is lowered, you may push the unit with the Low-Boy handle **G**. To deploy the handle, pull it out horizontally until the pins lock into the grooves, then lift to desired angle. After use, slide in completely horizontally.
8. Insert or remove the IV Pole as desired **O**. An Accessory Socket **I** is located on either side of the unit so that the IV Pole is never in the way when removing the safety stretcher or table top.
9. Plug the lift into a wall outlet for overnight charging at least once a week.

Safety

Used properly, this product is designed to provide safe, trouble-free operation. All electrical components are UL-Certified and all mechanical parts are built to exacting specifications. Throughout this manual, possible hazards are identified, and appropriate instructions to avoid such hazards are provided. In some cases, this manual points out the consequences of disregarding such instructions. Olympic Veterinary uses the following system for identifying safety hazards:

Danger – Immediate hazard that will result in severe personal injury or death.

Warning – Potentially hazardous conditions which, if ignored, could result in severe personal injury or major damage to the equipment.

Caution – Potentially hazardous conditions which, if ignored, could result in minor personal injury or minor damage to the equipment.

The user should be aware that this lift is a powerful machine with moving parts capable of causing injury if proper precautions are not taken. The lift is raised and lowered by means of a powerful electrical actuator, and care must routinely be taken to assure that hands, feet and other body parts are not in the path of the lift mechanism.

Please read and follow the instructions in this manual, including all safety instructions and precautions, carefully and completely.

Unpacking and Set-Up

Your Olympic Versa-Lift, Model 50701, or 50703 arrives fully assembled.

Transit damage: If you suspect concealed product damage, then please save all packaging and contact Olympic Veterinary immediately at 1-800-789-6867.

Unpacking: Olympic Veterinary tests and inspects every unit prior to shipment. Once all packaging materials have been removed, inspect the unit carefully for signs of damage to the electrical components and check all connections for tightness. Please report any claims regarding initial manufacturing quality within 10 days of receiving product.

Before first use: Locate the detachable power cord and plug into the Lift's AC Power Connector (**M**) – see page 3) for at least 24 hours to fully charge battery.

Operation

Loading and Unloading

1. Position the Versa-Lift on a level surface and lock the 2 Front Total-Lock Casters **A** and the 2 Rear Directional Casters **B**.
2. Care should be taken to assure that the top (Soft Stretcher or Hard top) is fully engaged on the 4 platform retention posts **G**.
3. The patient should be placed in the center of the platform. Off-center loads are unstable and may reduce the load capacity of the unit.
4. If the patient is active or may move around during transport, secure to the platform using the two integrated Velcro restraining straps.

Warning: Do not lift a load that exceeds the maximum rated load capacity; 250 pounds with the Hard Top Stretcher or 200 pounds with the Soft top Stretcher. Note that this capacity is reduced if the load is off-center.

Warning: Do not load or unload the lift while it is moving up or down.

Warning: The lift may be used briefly in transporting patients in wet conditions, but should not remain in extremely wet environments for extended periods. Nor should any part of the lift be submerged.

Height Adjustment

The height of the platform is controlled by a Foot switch **N** located at the back of the unit. The Versa-Lift can be lowered by pressing on the right side of the Foot switch and can be raised by pressing on the left side of the Foot switch. As a safety feature, the unit will stop moving as soon as the operator's foot is removed from the Foot switch.



Figure 2

Warning: As the lift moves up and down, “pinch points” are created where the scissor legs cross, where the upper platform comes to rest on the lower platform, and in the path of the rollers. Care should be taken to ensure that no part of the operator or patient, or any foreign object, is in the path of the scissors.

Caution: If the lift fails to move or exhibits strange sounds or movements, stop immediately and do not operate further until it has been checked and repaired.

Steering and Braking

The lift travels on 4 high-quality hospital-grade casters. The 2 casters at the front of the unit (with RED locking tabs) are Total-Lock Casters **A**. When engaged, these prevent the lift from rolling forward or backward.

The 2 casters at the back end of the unit (with GREEN locking tabs) are Directional Casters **B**. They are fitted with directional locks that prevent swivelling while still allowing forward motion. To engage the directional locks, push the lift forward until the wheels on these casters are in-line with the cart, then press down on the 2 green tabs.

Lock or unlock casters based on how cart will be used:

- **Normal transport** – Rolling and steering – all 4 casters unlocked.
- **Stationary use** – Treatment Table, battery charging, loading, unloading, etc.
CAUTION: All 4 casters must be locked.
- **Transporting heavier loads or when transporting over long distances** – 2 front casters (red brake tabs) unlocked. 2 rear casters (green brake tabs) locked. **CAUTION:** When transporting heavier loads, lift will not move sideways. Do not push lift sideways.

Note: It is recommended that the 2 Directional Casters **B** be engaged when pushing the lift over long distances, especially outdoors, where sideways movement is not required; and when pushing the cart alone, without the benefit of a second operator guiding from the rear.

Interchangeable Tops

The Olympic Versa-Lift comes with a Soft Stretcher and a Hard Top Stretcher. Care should be taken to assure that the selected top is securely seated on the 4 Retention Posts **G**. When center-loaded, the Hard Top Stretcher can hold up to 250 pounds and the Soft Top up to 200 pounds.

The Soft Stretcher includes a removable Herculite® stretcher cover. This cover should be wiped clean with a mild disinfectant between uses. It is not suitable for machine laundering. The Hard Top should similarly be wiped clean with a mild disinfectant between uses.

When transporting an awake animal, or an anesthetized animal without the help of an assistant, care should be taken to secure the patient with the provided Velcro® restraining straps.

Low Boy Handle

The Versa-Lift can be used as a Low-Boy transport when the platform is fully, or even partially, lowered. To use the Low-Boy Handle **C**, pull it out horizontally until the pins lock into the grooves **D**, then lift to desired angle. After use, slide in completely horizontally until the pins at the end of the handle lock into place **E**.

The handle is designed for pushing and may be adjusted to whatever angle is most comfortable for the operator.

IV Pole

The lift comes with an IV Pole that fits into either of the pole sockets at the rear of the unit **I**. Care should be taken to align the slot on the bottom of the pole with the crossbar inside the post. This assures a snug fit and prevents the IV Pole from rotating.

Caution: When moving the lift through doorways with the IV Pole in place, care should be taken to assure the top of the IV Pole clears the door jam.

Swivelling Instrument Tray (optional)

Plugs in to either of the Accessory Sockets **I**.

Headrest for Olympic Versa-Lift (optional)

Plugs in to the 2 Accessory Sockets **I**. Extends surface by 10".

Battery

The lift is electrically operated using an on-board 24 volt lead-acid Battery Pack **K** that snaps into a built-in Control Box/Charger **L** located between the scissors legs. Properly maintained, the battery should provide many years of reliable service. To replace, reach under the top of the battery, pull up on the release lever and slide the battery out.

Connecting the Power Cord

Your lift's AC power connector is located just above and to the left of the Foot switch **M**. You may connect the unit to any 120V/60Hz wall outlet with the provided 10' extension cord.

Charging

Before first use, the battery should be charged for 24 hours. Thereafter, recharging the battery fully may require up to 6 hours of continuous charging. Leaving the unit connected to AC power beyond 6 hours will not harm the battery or compromise battery life.

Best practice is to connect the lift to AC power once a week and leave it connected over night. If the battery is routinely recharged it will last up to 5 times longer than a battery that is routinely allowed to discharge to empty.

<p>Note: Be sure to unplug the unit before attempting to raise or lower the lift. As a safety precaution, the lift will not operate as long as the unit is still connected to AC Power.</p>

Indicators

Indicator lights on the faceplate of the controller provide information about charging status, as follows:

Green and Yellow On: Unit is connected to AC Power and battery is charging.

Green Only: Battery is fully charged. Unit may be unplugged from AC power.

Note: There are no external fuses on this device. There is, however, a current cutoff inside the control box that is set at 7 Amps. This means that if the actuator were ever overloaded, or in a bind situation, there is a mechanism inside the control box that cuts current to the motor. Once this current cutoff has been activated, it requires that you remove your foot from the Foot switch, and press the switch again to attempt to operate the actuator. If the actuator is still overloaded, it will not move. The user must either remove load from the top, or remove the actuator from the bind condition.

Warning: The battery contains lead acid and should not be punctured or damaged. Seek urgent medical advice if acid contacts skin or clothing. Ensure that the battery is disposed of safely and according to local regulations.

Warning: There is a ventilation hole in the back of the battery pack. This hole must remain clean and unblocked to ensure that positive pressure within the battery is released.

Preventive Maintenance

The Olympic Versa-Lift is a durable piece of equipment designed to provide many years of trouble-free performance with only minimal maintenance.

The following outlines the recommended schedule, under normal use, for cleaning, lubrication and inspection. Heavy use or use under severe conditions might dictate shortening these intervals.

Procedure	Frequency
Cleaning	Daily
Charging	Weekly
Cleaning and lubricating the glide channels	Monthly
Lubricating casters and pivot points	Every 6 months (more often in wet conditions)
Inspecting frames and fasteners	Every 6 months

Cleaning

The lift should be wiped down daily with a soft cloth, using either plain water or a mild disinfectant. All surfaces may be cleaned in this way, although care should be taken to minimize the amount of water or other fluids used on the battery/controller and around electrical connectors.

Properly maintained, the powder coated finish on your lift should look good even after years of service. While minor scuffing and scratching is to be expected over time, it can be minimized by avoiding the use of abrasive cleaning products or abrasive applicators such as “steel wool” or hard plastic scrubbers.

Caution: The lift should never be washed down with a power washer as this can damage sensitive electronics and remove lubricant from the rollers and casters.

Cleaning and Lubricating the Glide Channels

The scissors mechanism that lifts and lowers the lift terminates with glider blocks **P** that ride in aluminum channels at the top and bottom of the unit. These channels should be inspected regularly and wiped clean to assure smooth movement. They should also be sprayed with a liquid lubricant such as Boeshield T-9.

Lubricating and Inspecting Casters

The hospital-grade casters on your lift are designed to provide years of reliable service. Regular lubrication, however, is important in maintaining optimal performance. Under normal operating conditions, the casters should be lubricated every 6 months. However, when operated frequently in wet conditions, monthly lubrication is recommended.

Each caster has two points that require lubrication – the swivel mechanism **X**, and the wheel axle **Y**. Olympic recommends the use of a spray-on liquid lubricant such as Boeshield T-9. When lubricating the swivel mechanism, use just enough grease to cover the ball bearings, then turn the wheel several times in both directions to distribute evenly. When lubricating the wheel axles, apply just a spot of lubricant to each side.

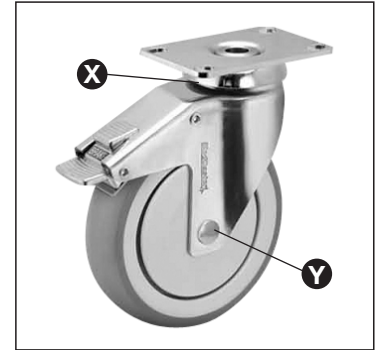

Figure 3

Casters should also be inspected regularly for signs of wear that indicate time for replacement. Continued use of excessively worn casters may compromise overall performance and braking ability.

The following are all indications that a caster needs to be replaced:

1. Swivel is loose or wobbly.
2. Swivel is too tight, even after lubrication and cleaning.
3. Wheels are excessively pitted, missing chunks of rubber or have developed flat surfaces. These conditions will make steering imprecise and difficult.
4. Brakes slip due to worn wheels.
5. Swivel locks fail to hold.

Caution: Brakes should be tested regularly and before engagement on any unlevel surface. The lift should not be used unless all brakes are operational.

Lubricating Pivot Points

Lubricant should also be applied to the two pins that retain the linear actuator. Olympic recommends spraying these pivot points with a liquid lubricant such as Boeshield T-9.

Trouble Shooting

Problem	Possible Causes	Remedies
Lift will not raise or lower.	Battery is out of power.	Recharge the battery, making sure that the green indicator light illuminates, which confirms connection to a live wall outlet.
	AC power cord is still connected to the controller.	Disconnect power cord. Unit will not operate when connected to wall power.
	Foot switch cable is disconnected.	Check that the cable from the Foot switch to the controller is properly connected and not frayed.
	No power to the actuator.	Check that power cable from the actuator is properly connected to the control box and not frayed.
	Other	If all of the above actions fail to cure the problem, call Olympic Veterinary Technical Support at 800-789-6867.
Lift raises OK, but then slowly lowers by itself.	Load exceeds rated 250 pounds capacity or is off-center.	Lift should not be loaded with more than 250 pounds, centered on platform. Remove excess load.
	Linear Actuator brake or motor coupling may be worn out.	Call Olympic Veterinary Technical Support for further instructions at 800-789-6867.
Makes noise or vibrates while raising or lowering.	Load exceeds rated 250 pounds capacity or is off-center.	Lift should not be loaded with more than 250 pounds, centered on the platform. Remove excess load.
	Dirt or hair has accumulated on scissor gliders.	Wipe down the glide tracks on top and bottom assemblies to remove debris.
	Pivot points require lubricant.	Lubricate all pivot points as described above under Preventive Maintenance.
	Other	If all of the above actions fail to cure the problem, call Olympic Veterinary Technical Support at 800-789-6867.

Specifications

Olympic Versa-Lift – Model 50701, 50703

Capacity – 250 pounds with centered load
 Table size – 24" x 51" (hardtop) or 22" x 46" (stretcher)
 Raised height – 42" (hardtop) or 39.5" (with Soft Top Stretcher)
 Overall maximum dimensions – 56"L x 24"W x 12"H
 Casters – 2 Total-Lock and 2 in-line locking
 Battery – 24 Volt DC lead-acid type
 Charger – 120V/60Hz
 Weight – 68 pounds

Ordering Information

- 50701** – Olympic Versa-Lift complete with Pull-Out Handle, IV Pole, Soft and Hard Stretchers.
50703 – Olympic Versa-Lift complete with Pull-Out Handle, IV Pole and Hard Stretcher.
50705 – Olympic Versa-Lift with new Quick-Lock Casters. Complete with Pull-Out Handle, IV Pole, Hard and Soft Stretchers, Instrument Tray, 2 Foot switches.

Optional accessories

- 50680 – Olympic Soft Stretcher
- 50606 – Replacement Cover for Olympic Soft Stretcher
- 50685 – Olympic Hard Top Stretcher (included with all versions)
- 50780 – Swivelling Instrument Tray for Olympic Versa-Lift
- 50781 – Headrest Extender for Olympic Versa-Lift

Service

If you have any questions or experience any difficulties with this product, please call Olympic Veterinary Customer Service at 1-800-789-6867 between 7:30 a.m. and 4:30 p.m. Pacific Time, Monday-Friday. We are eager to help you, and in many cases will be able to resolve the problem for you over the phone.

If a repair is required, you will in some cases be asked to return the unit (or one of its components) to the Olympic Veterinary repair facility. This will require a Return Merchandise Authorization number (RMA), which is issued by a customer service representative.

Note: In no case should this product or any of its components be returned without the advance approval of Olympic Veterinary and a valid RMA number.

For repairs within the specified warranty period, the user pays the cost of shipping the original component to Olympic Veterinary and Olympic Veterinary pays the cost of shipping the replacement back to the user. For components not under warranty, the user pays shipping both ways.

In many cases, repairs can be completed by the clinic's staff using the provided parts and instructions. Where out-of-warranty repairs require the services of an Olympic Veterinary technician, the user will be billed at the then prevailing rate, to be quoted in advance.

Replacement Parts

The following parts are readily available from Olympic Veterinary and can be easily replaced by the user's technical staff.

- 6507-002 Front Total-Lock Casters
- 6507-003 Rear Directional Casters
- 6507-025 Battery
- 50606 Stretcher Cover

3-Year Unconditional Warranty

The Olympic Versa-Lift (model 50701, 50703) is unconditionally warranted for a period of three (3) years from the date of invoice.

Olympic Veterinary will elect to repair or replace a defective component without charge within the warranty period. The charge for shipping the defective component is the responsibility of the buyer and must be accompanied by an RMA number. The shipping charge to return the component to the buyer is the responsibility of Olympic Veterinary, Inc. In some cases, at Olympic Veterinary's sole discretion, it may be possible to provide the user with a repair kit, authorizing the user's technical staff to complete the repair. In such cases, the labor cost shall be the sole responsibility of the user.

This warranty is not valid for damage resulting from negligence, accident, unreasonable use, abuse or misuse, exceeding weight limits or altering the product without prior Olympic Veterinary authorization.

Olympic Veterinary expressly disclaims and excludes any liability for consequential, incidental, indirect or punitive damages or financial loss to people or property resulting from any breach of warranty or from the improper operation of this equipment.

This limited warranty is provided to the original purchaser and is not transferable. This constitutes the complete and final agreement for Olympic Veterinary's Versa-Lift, model 50701, 50703.

Contact Us

Olympic Veterinary Corporation, Customer Service

9311 SE 36th Street, Unit 220
Mercer Island, WA 98040

Phone: (800) 789-6867

Fax: (800) 905-0839

Email: info@OlyVet.com

NOTE: THIS IS NOT THE STREET ADDRESS TO BE USED FOR RMA RETURNS.

Detailed shipping instructions will be provided by customer service when a RMA is issued.